



# K40

## USER MANUAL

# CONTENT

---

- 1 PRODUCT INTRODUCTION** ..... 1
  - Parameters ..... 1
  - Outline dimension ..... 2
  - Packing list ..... 3
  
- 2 PRODUCTS DESCRIPTION** ..... 4
  - Overview ..... 4
  - Red cross line locating ..... 6
  - Driver adapter ..... 8
  - Sliding plate ..... 9
  - Cable PIN definition ..... 10
  
- 3 CONNECTION DESCRIPTION** ..... 11
  
- 4 FOCUS REFERENCE SETTINGS** ..... 13
  - For cutting ..... 13
  - For engraving ..... 14
  
- 5 PRECAUTIONS** ..... 15
  
- 6 MAINTENANCE** ..... 15

# 1. PRODUCT INTRODUCTION

## Parameters

Optical power:	40W~46W
Input:	24V 6A
Wavelength:	450nm ( $\pm 10$ nm)
Focus length:	40mm
Power adjustable:	TTL/PWM
PWM modulation:	0/3-12V, 0-5kHz
Air Assistance:	Built-in airway
Fan speed:	9000rpm
Operating temperature:	0-60°C
Interface:	2EDG-3.81
Material:	Aluminum & Copper
Module weight:	900g
Application:	Engraving & Cutting

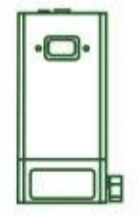

# Outline dimension (Unit: mm)

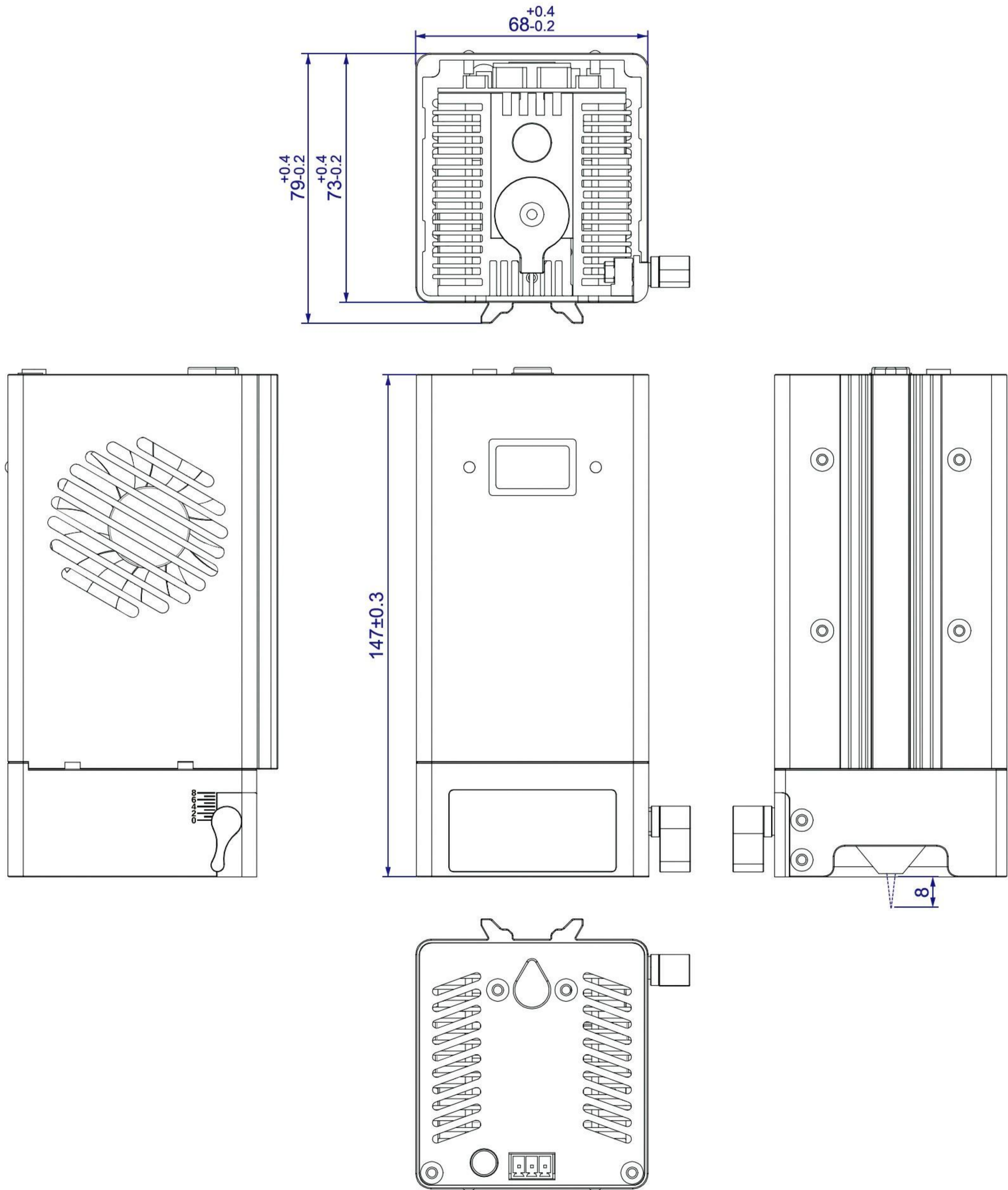

🔌 Packing list



Laser Module

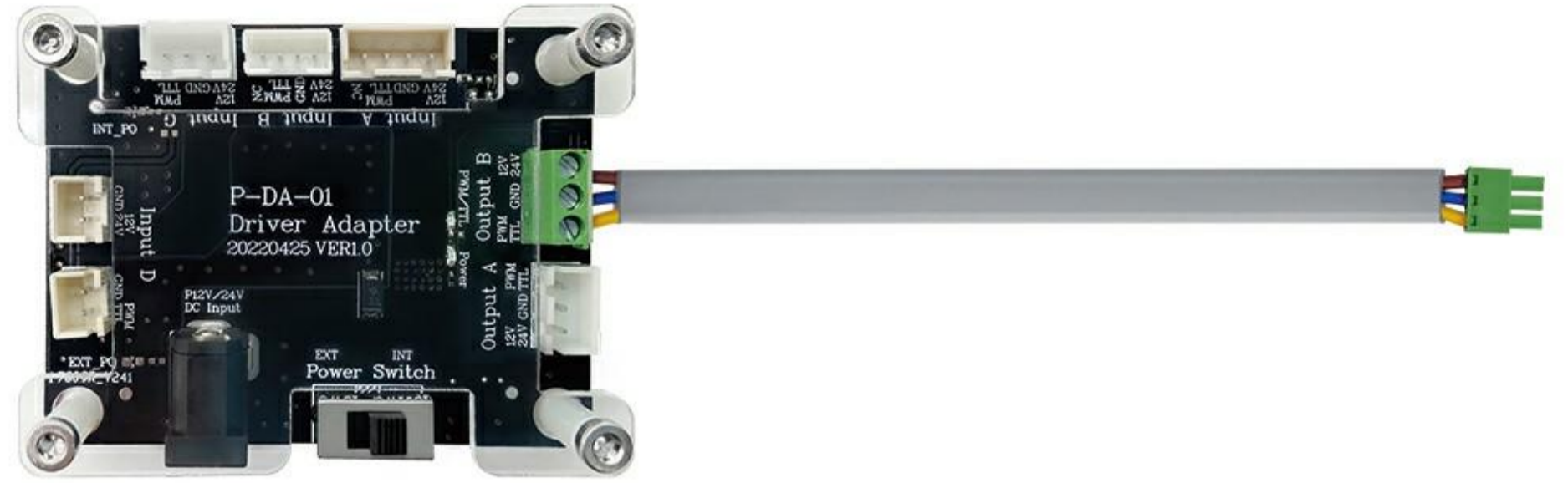

Driver Adapter & 30cm Input Cable

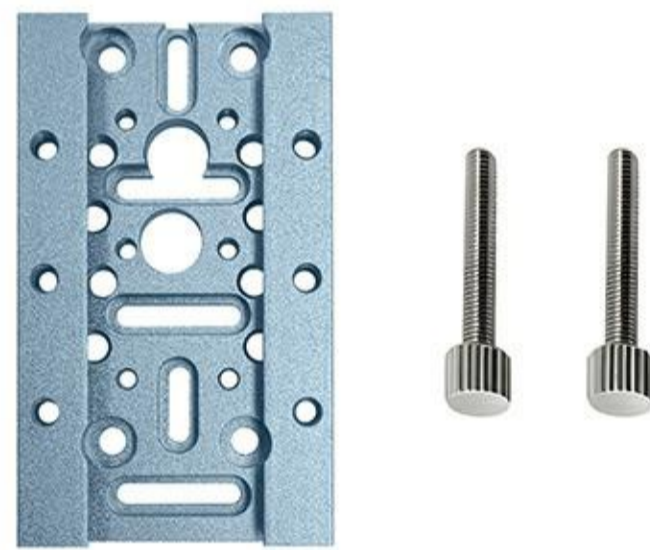

Sliding Plate



Spare Protective Lens



24V8A Power Adapter



Power Cable



Air Tube



60cm Adapter Cable



2.5mm Flat Screwdriver



2mm L-wrench

## 2. PRODUCT DESCRIPTION



### Overview

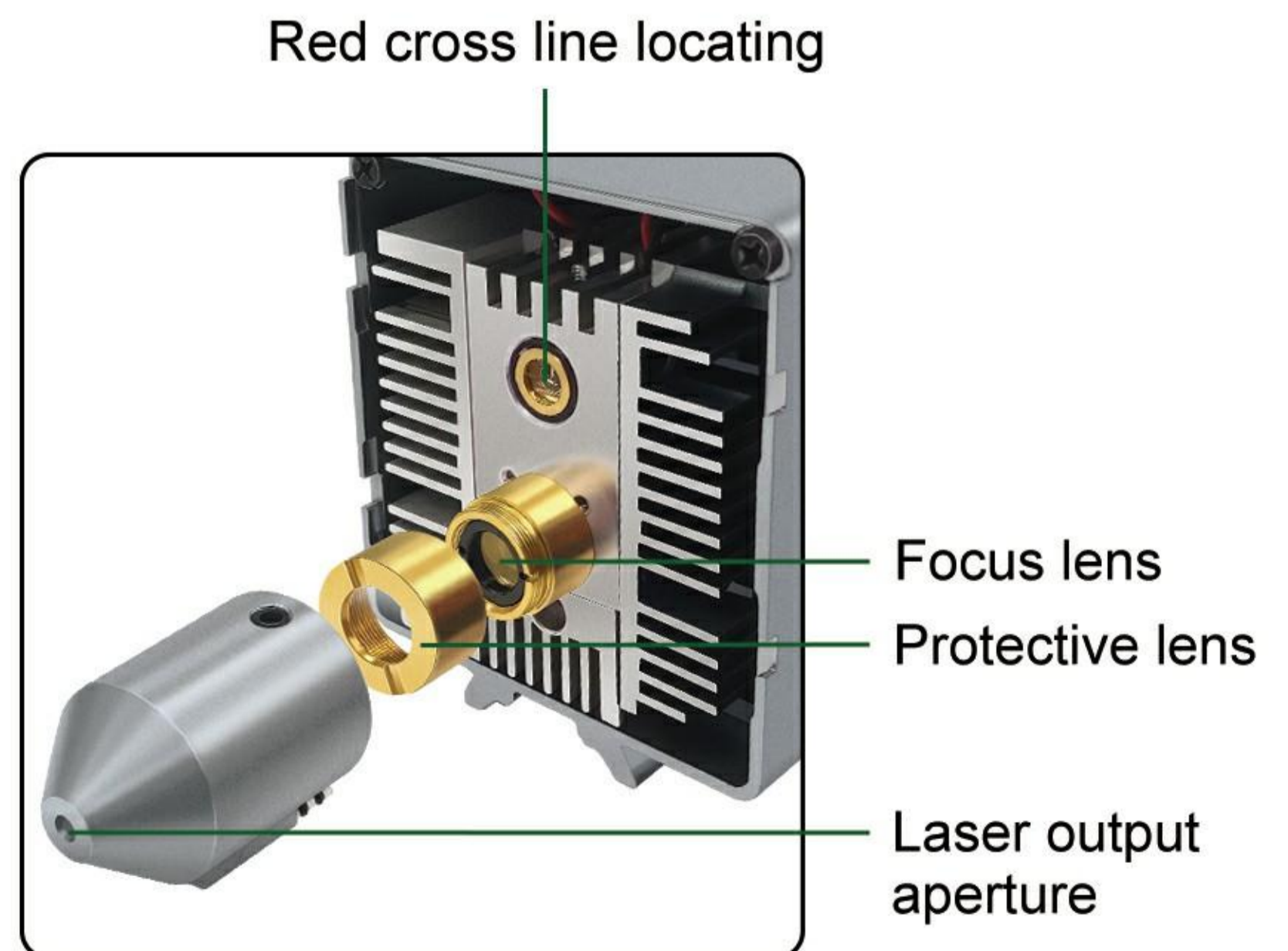
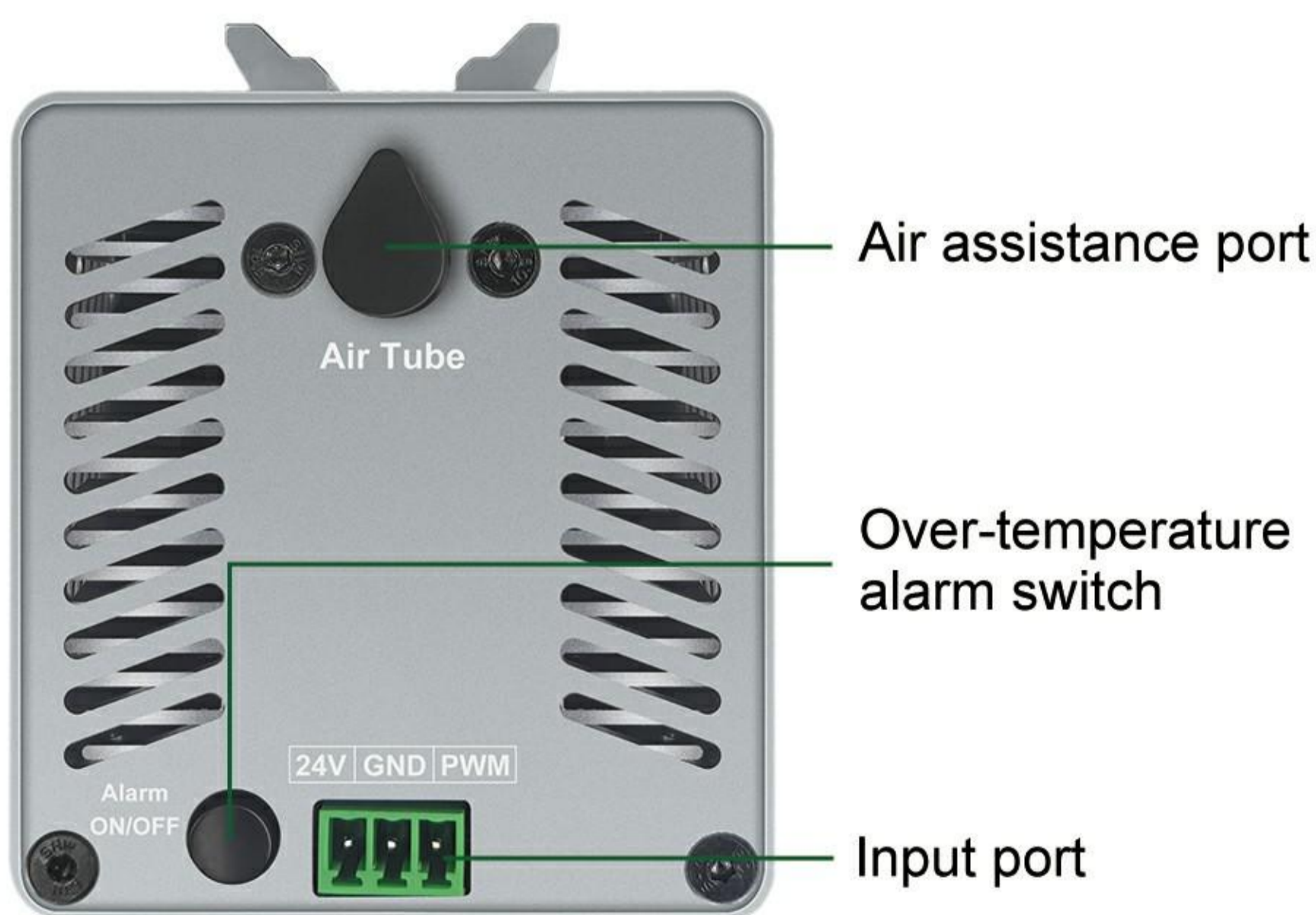
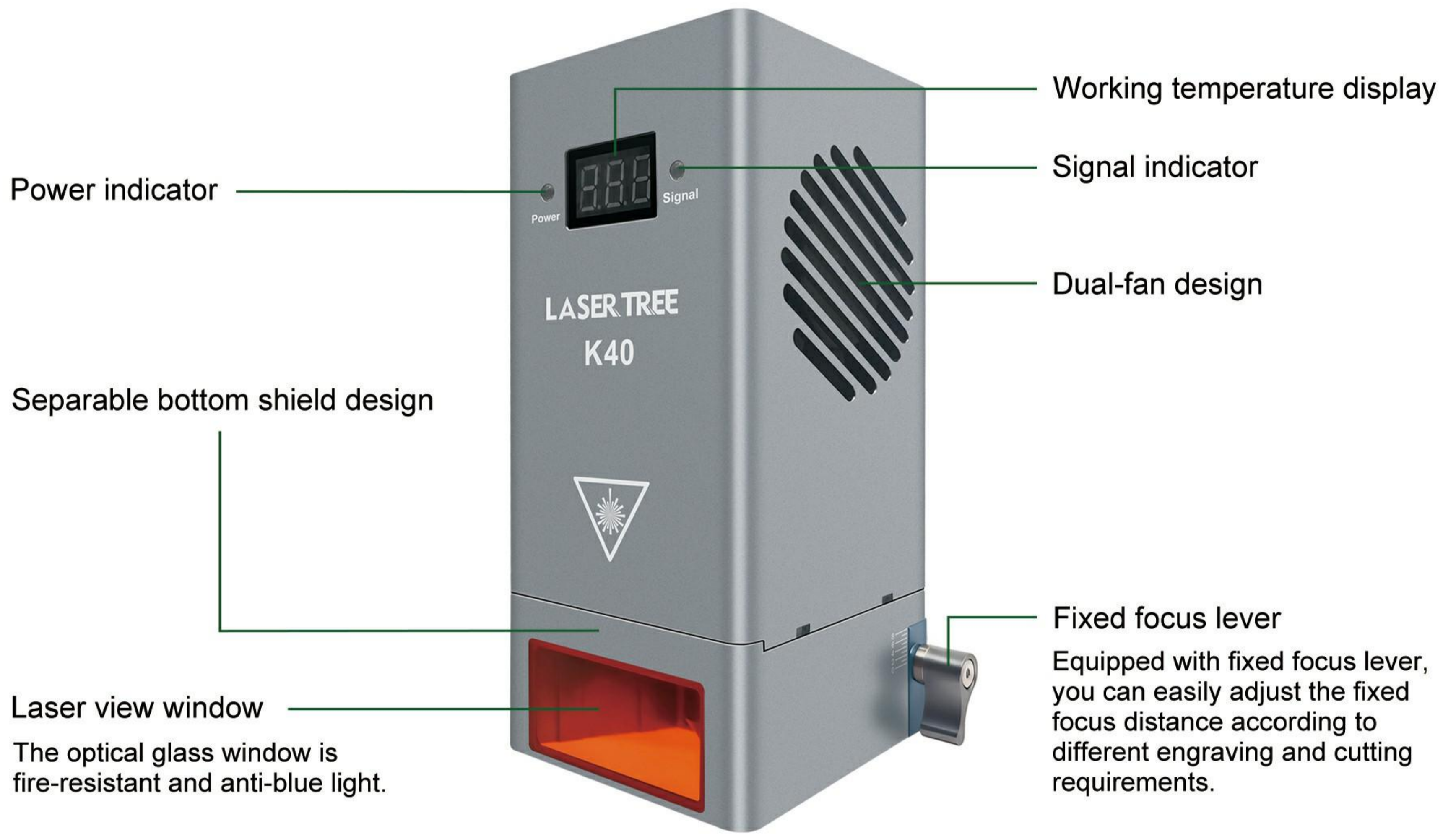



### Input port

Use 2EDG3.81 pluggable connector.

- VCC (DC24V)
- GND
- TTL/PWM in (0-5kHz)

### Air assistance port

Built-in air assist to get clean-cut edges and improve cutting performance.

#### Air pump suggestion:

- Air pressure and capacity:  $\geq 0.027\text{kPa}$ , 27L/min
- Air tube: outer diameter 8mm and inner diameter 5mm

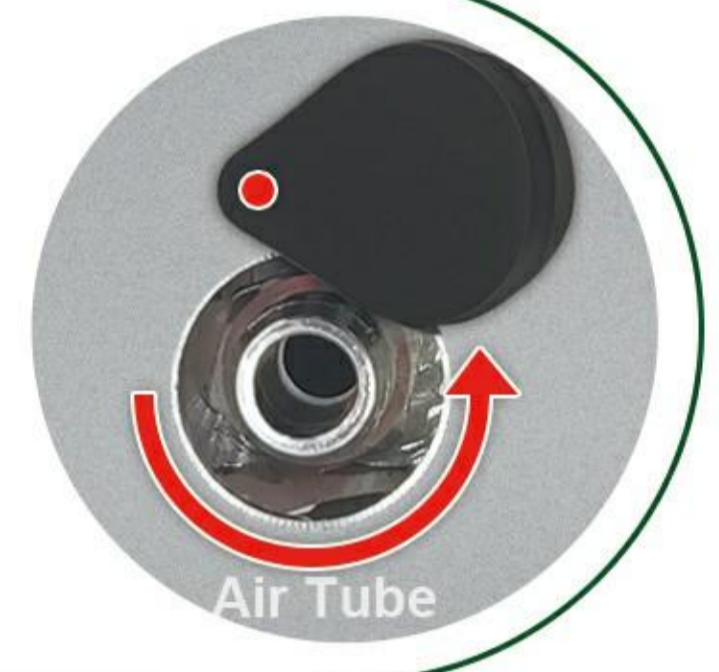

### Working temperature display

The output power stability and life time of laser module has strong relationship with working temperature of laser diode. With help of the built-in temperature sensor, K40 can display real-time working temperature.

We suggest the working temperature of the laser module is controlled below  $55^{\circ}\text{C}$  and the working environmental temperature below  $35^{\circ}\text{C}$  to get good power stability and durability.

### Over-temperature alarm switch

When the working temperature of the laser module is higher than  $55^{\circ}\text{C}$ , the buzzer will sound an alarm.



### Working status indicator

**Power indicator:** it is red when power supply is connected.

**Signal indicator:** it is green when signal is received.

✚ Red cross line locating

Help you to place the material to the position correctly.



Before

VS

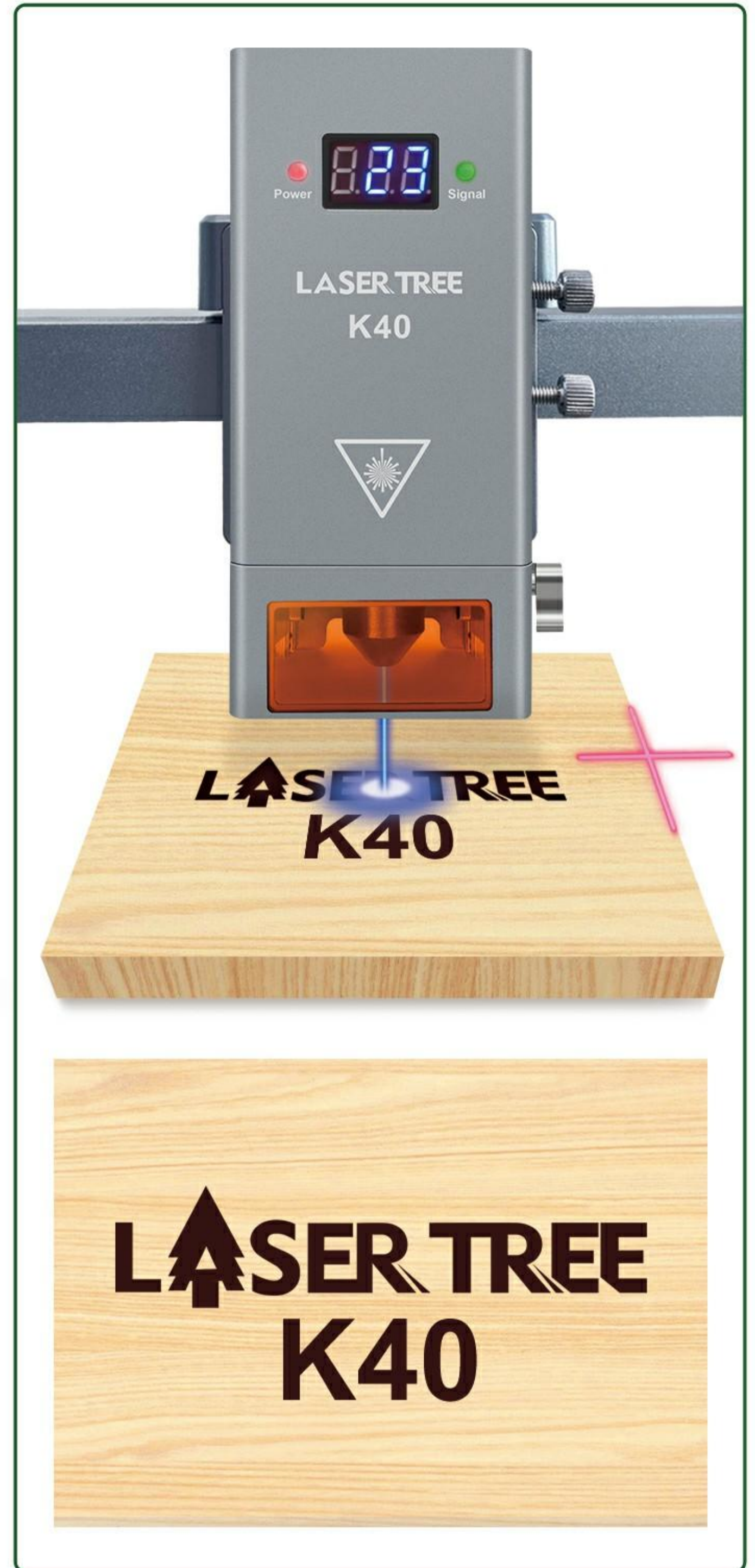

After

Focus positioning setting reference.



LightBurn Software settings

→ Device setting → Laser offset → Y axis: -21mm

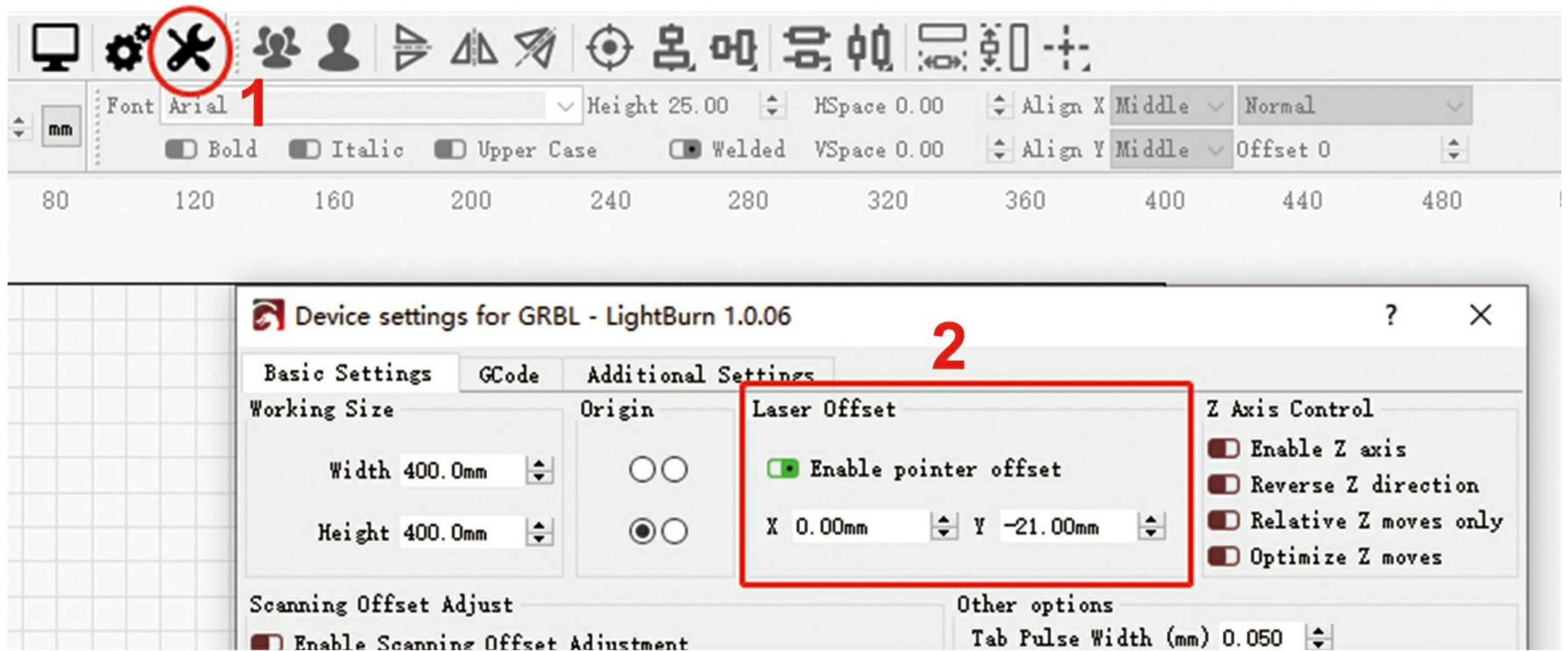

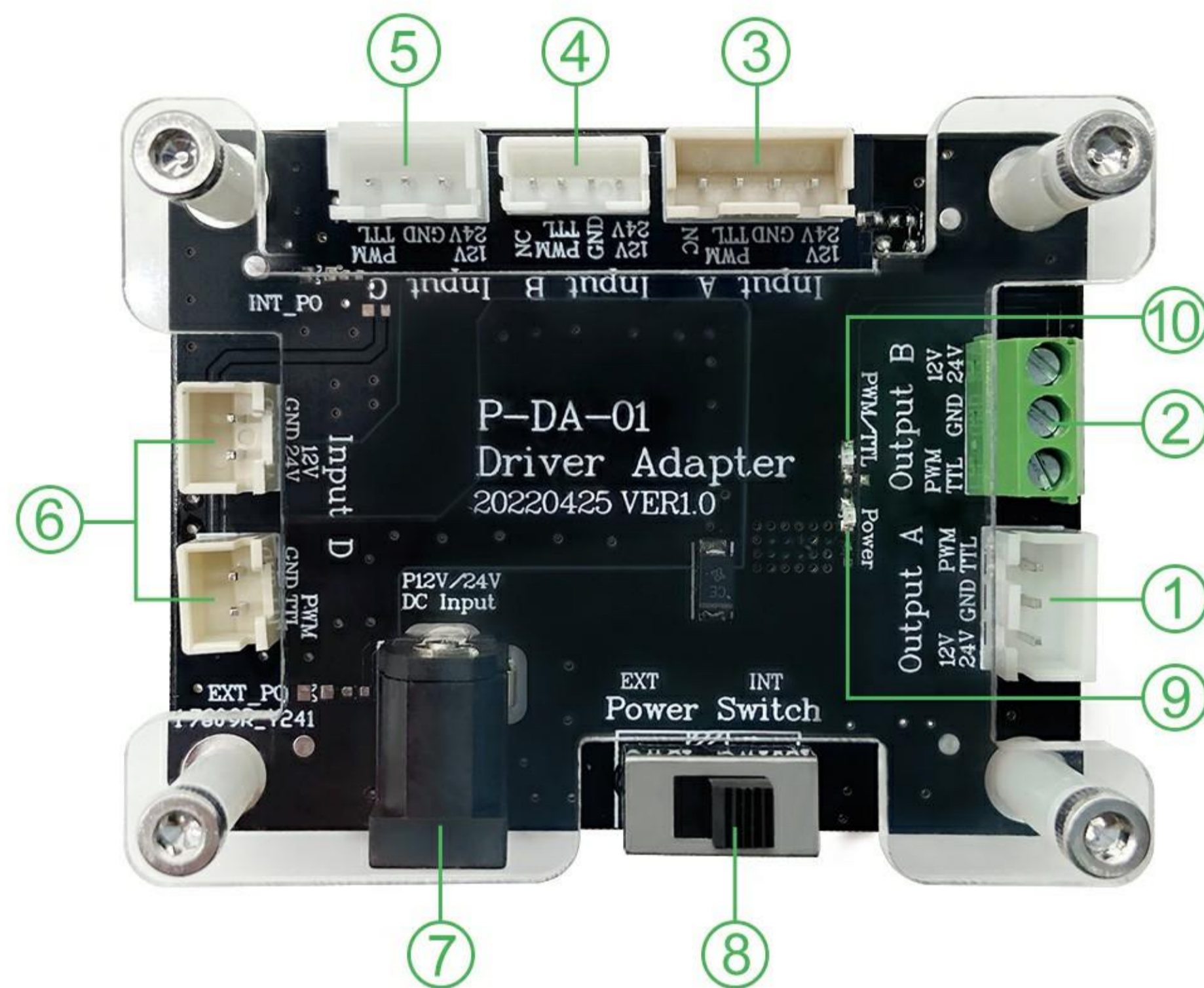

① Output A: 3PIN connector	② Output B: 3PIN connector
③ Input A: 4PIN connector	④ Input B: 4PIN connector
⑤ Input C: 3PIN connector	⑥ Input D: 2PIN connector
⑦ DC Input: 12V or 24V power adapter	
⑧ Power Switch: • EXT→External power supply • INT→Internal power supply	
⑨ Power indicator: It is red when the power cable is connected correctly.	
⑩ TTL/PWM indicator: It is green when the TTL/PWM cable is connected correctly.	

## Sliding plate

Multiple holes bring you widely installation compatibility.

Outline dimension (Unit: mm)

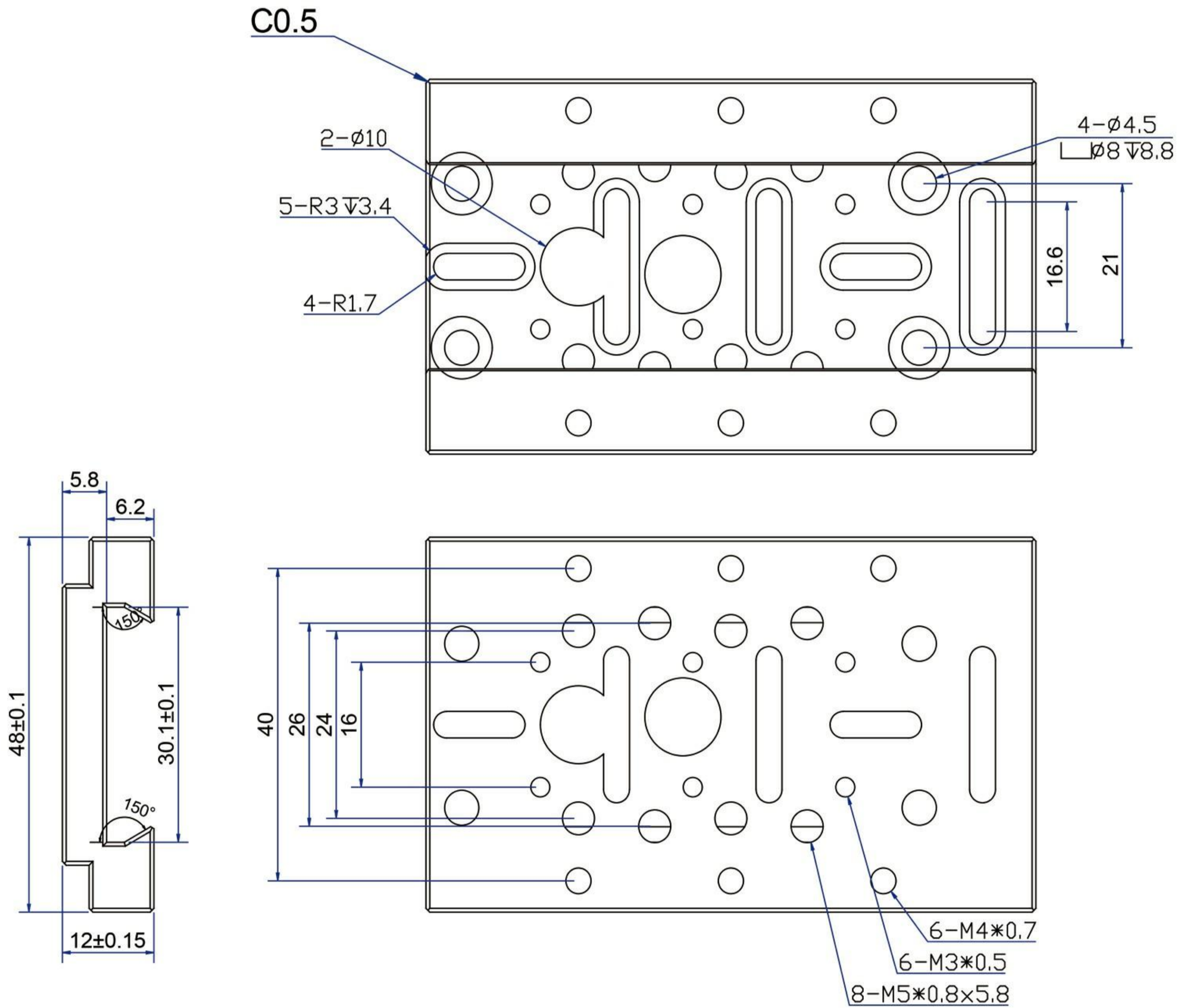

M4x20 Fasten screw\*2

Installation for sliding plate

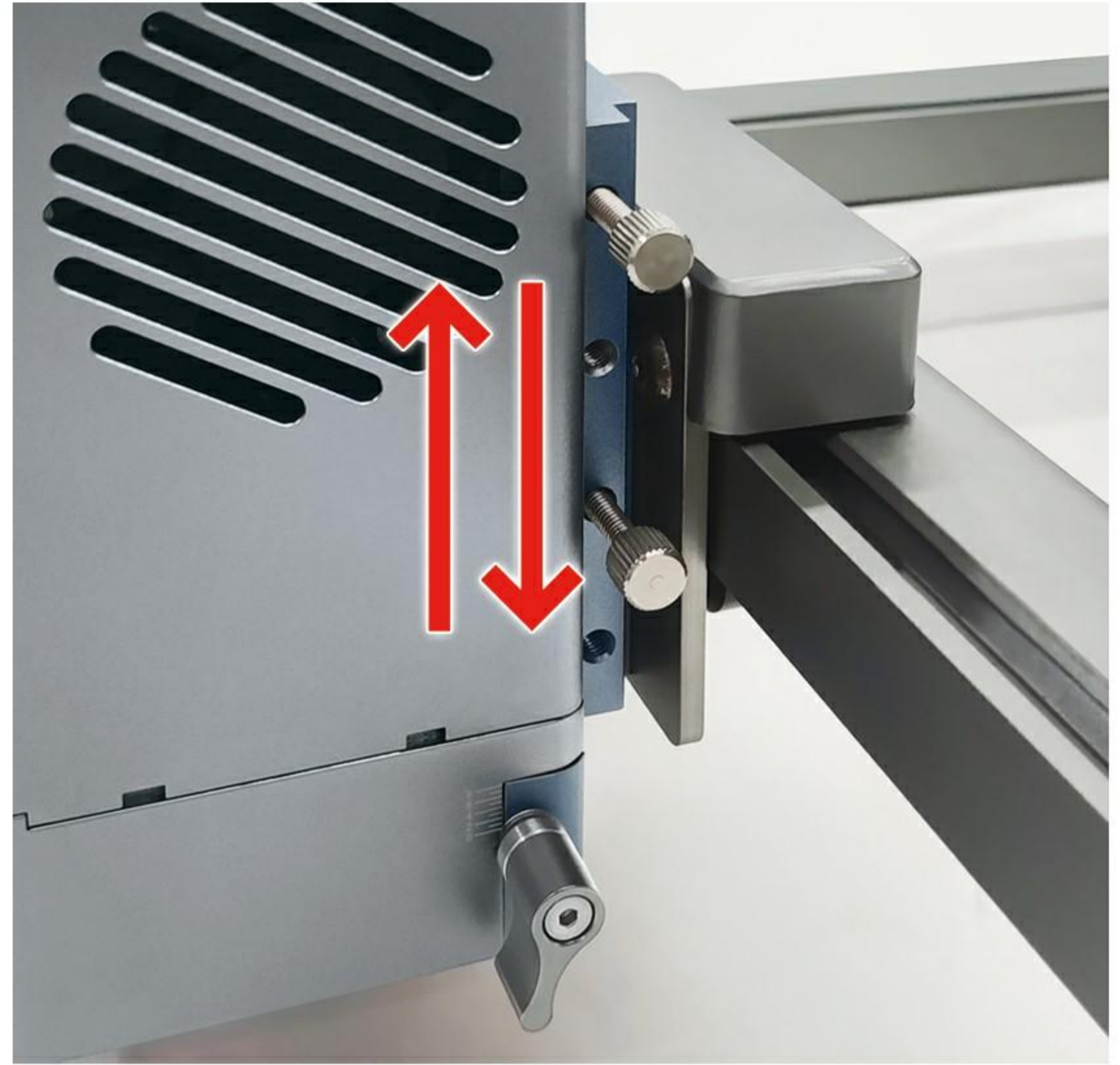
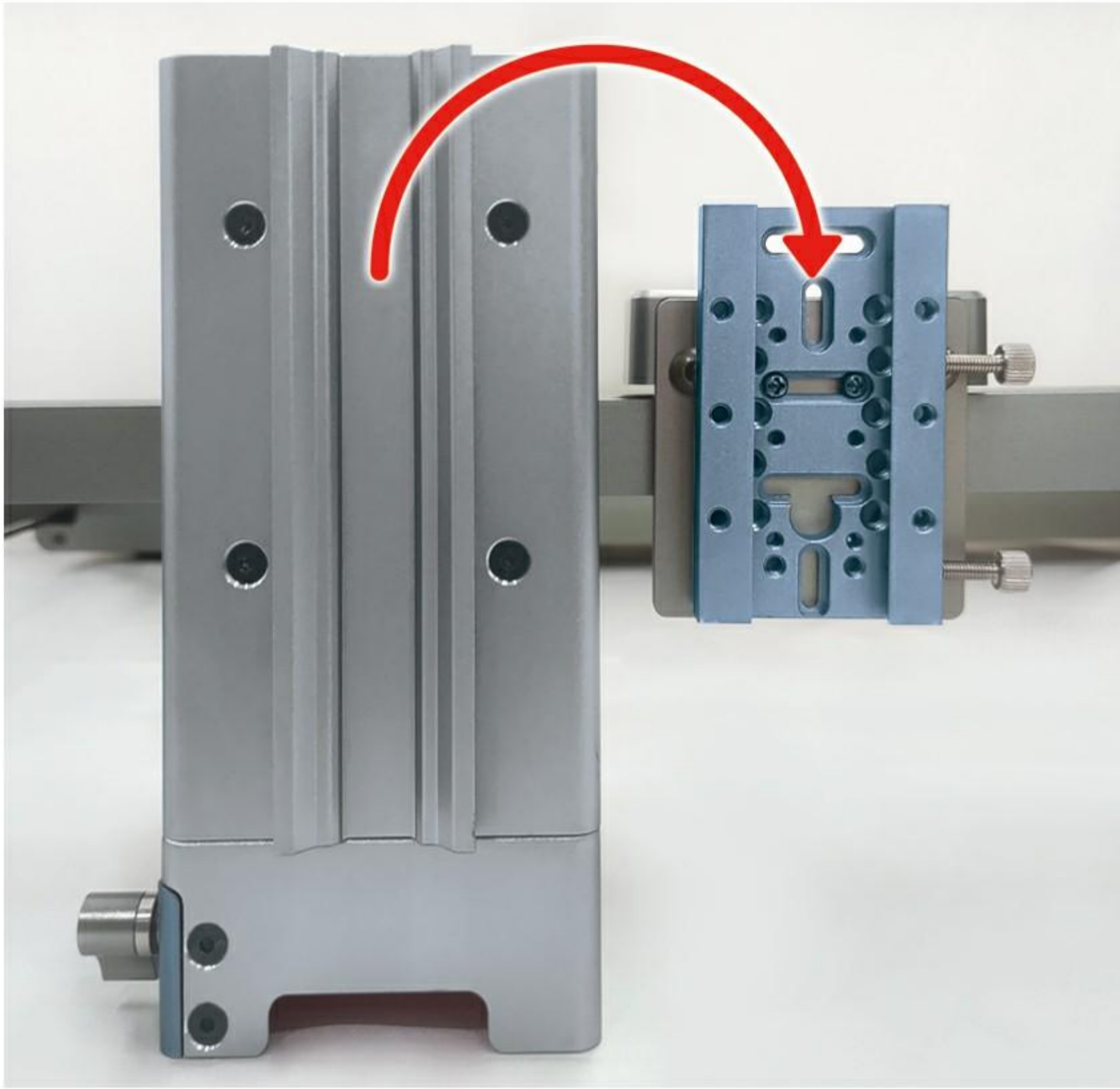

≡ Cable PIN definition

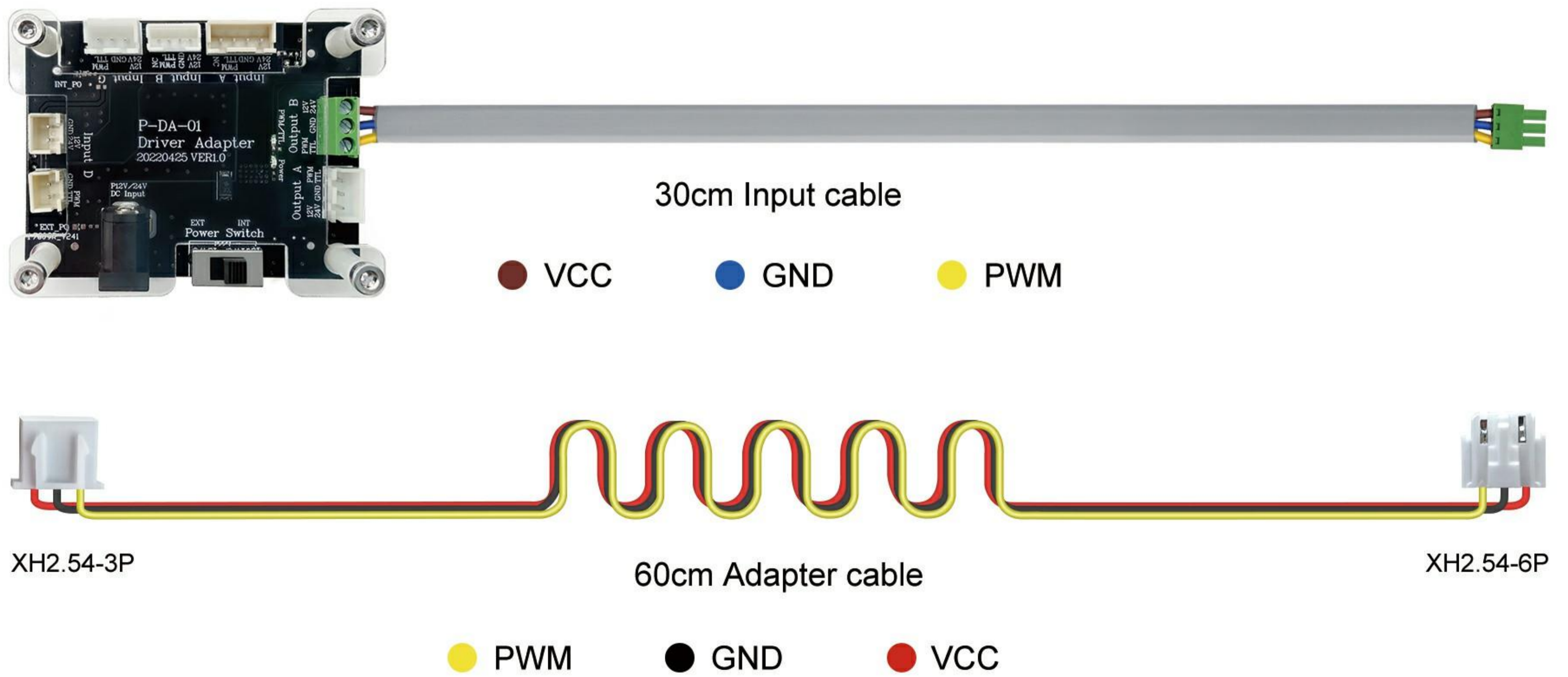

### 3. CONNECTION DESCRIPTION

Please check whether there is a PWM/TTL and GND output port on the engraver main board before connection.

- Step1** Connect one end of the input cable to the laser module and the other end to the corresponding output B port on the driver adapter.



- Step2** Connect the 24V power adapter to the DC input connector on driver adapter. Push the switch to "EXT" position and the power is provided by external power adapter.

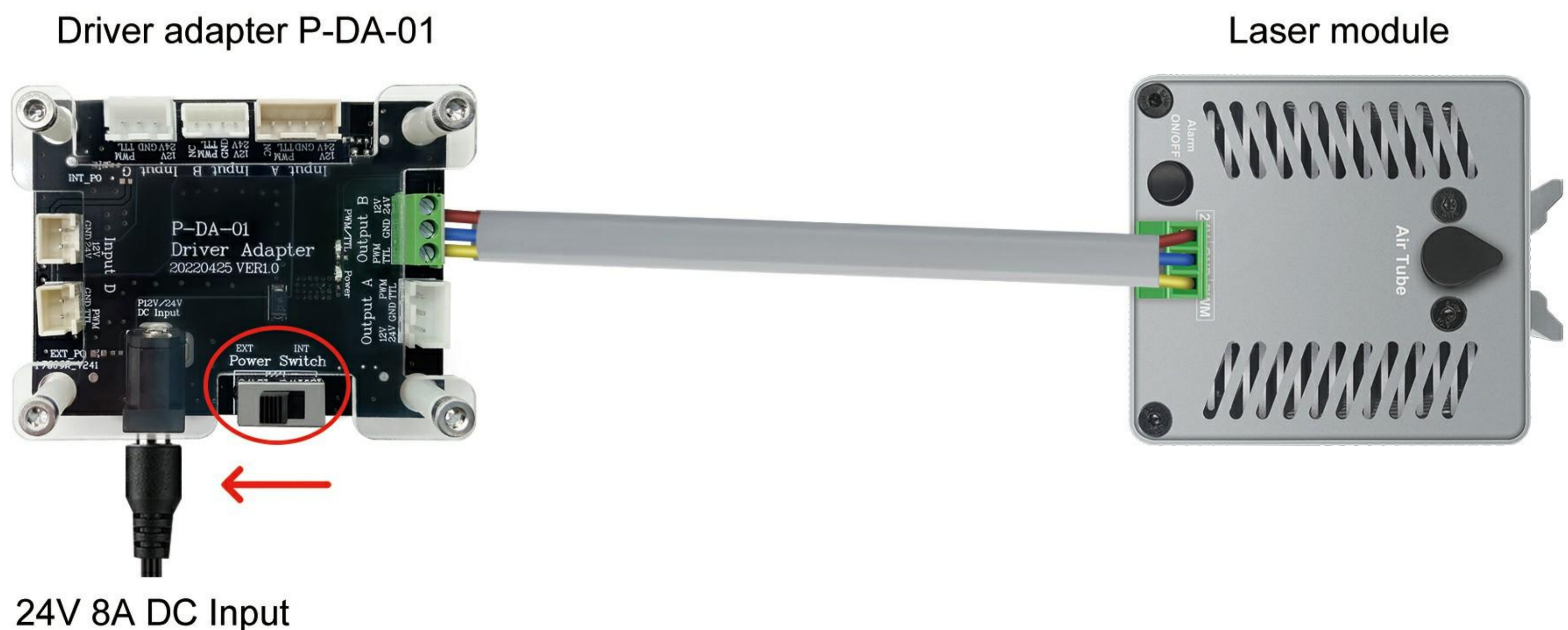

Step3

Connect the engraving machine main board cable to the corresponding input port on drive adapter.

(The picture below is a connection example. For more Input ports, please refer to the driver adapter description on page 8.)

Engraving machine main board

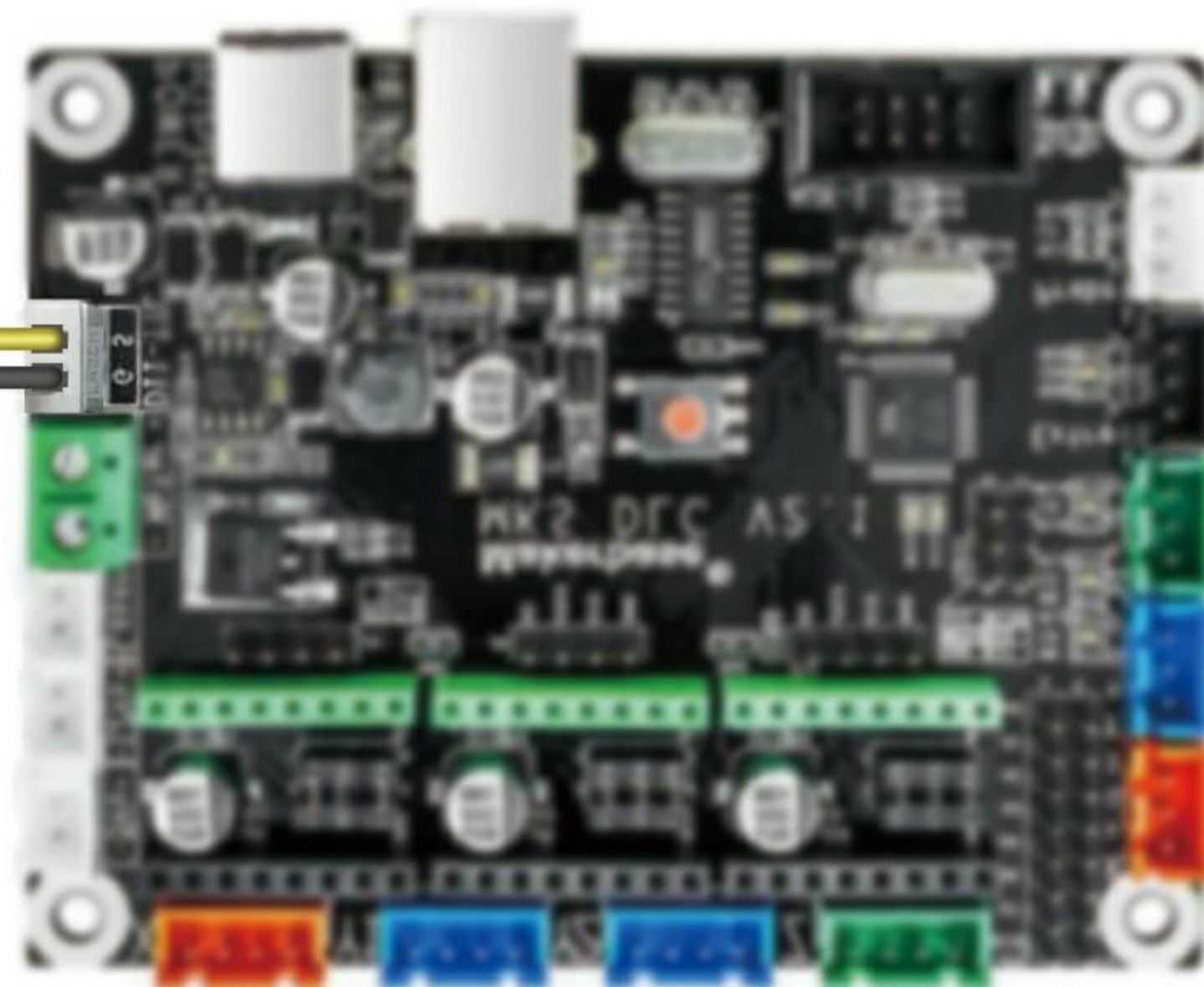

Driver adapter P-DA-01

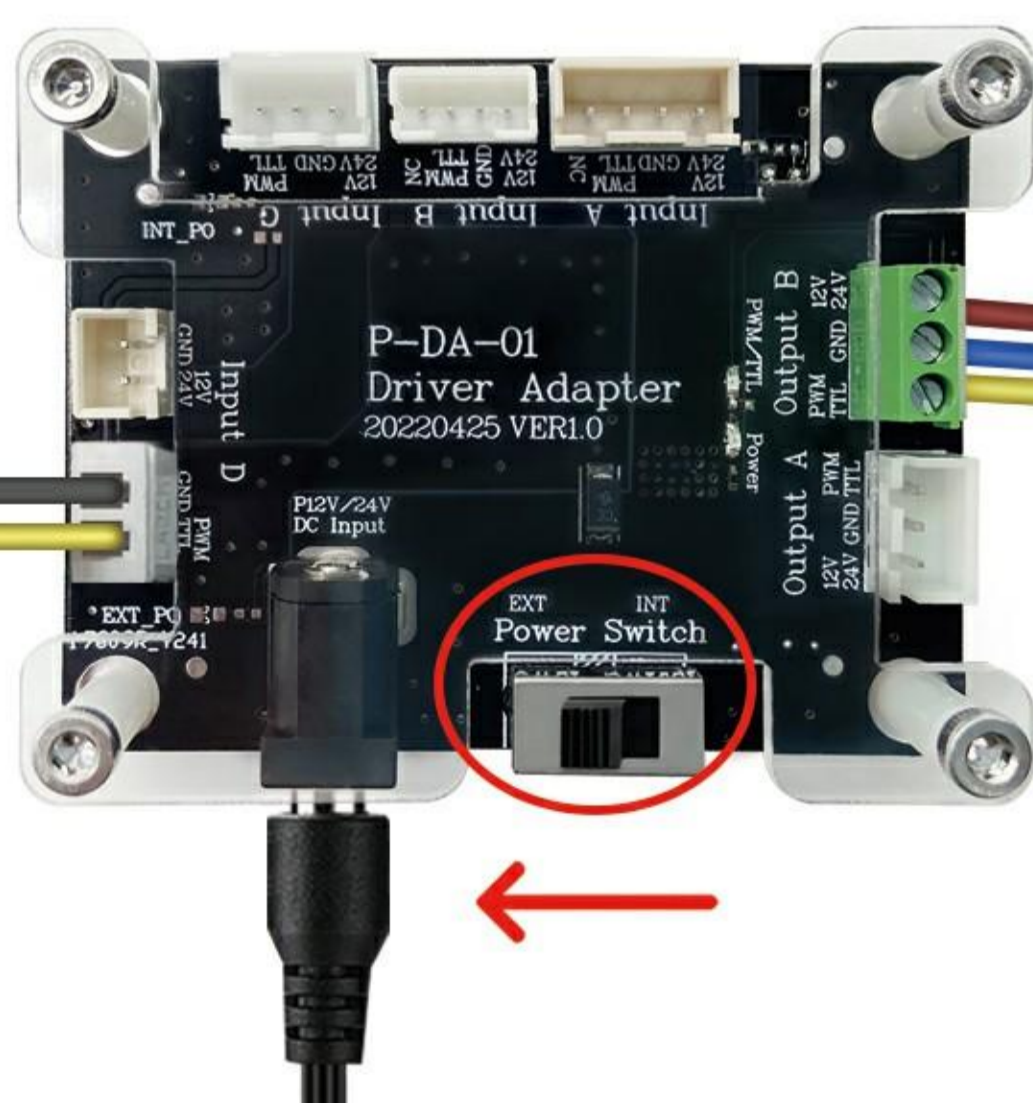

24V 8A DC Input

Laser module



## 4. FOCUS REFERENCE SETTINGS

The working focal length of the K40 laser module is 40mm.

 **For cutting**

Please make the focus locate lower than the cutting material surface according to the following.

### Reference settings for cutting

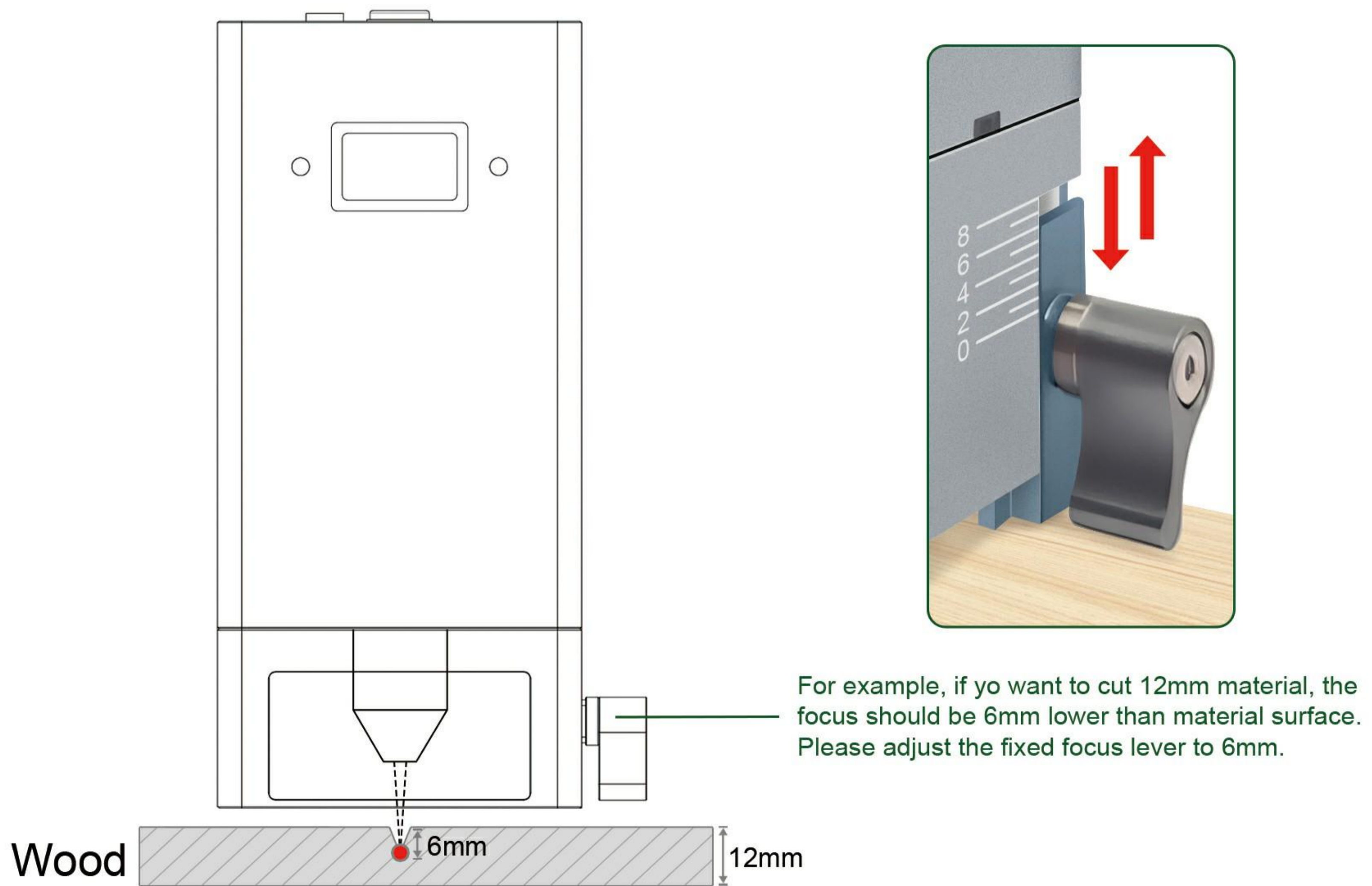

Fixed focus lever usage reference						
Material thickness	< 5mm	5mm	8mm	10mm	12mm	≥ 15mm
Fixed focus lever	0mm	2mm	4mm	5mm	6mm	7mm

 For engraving

Please make the focus locate on the engraving material surface.

### Reference settings for engraving

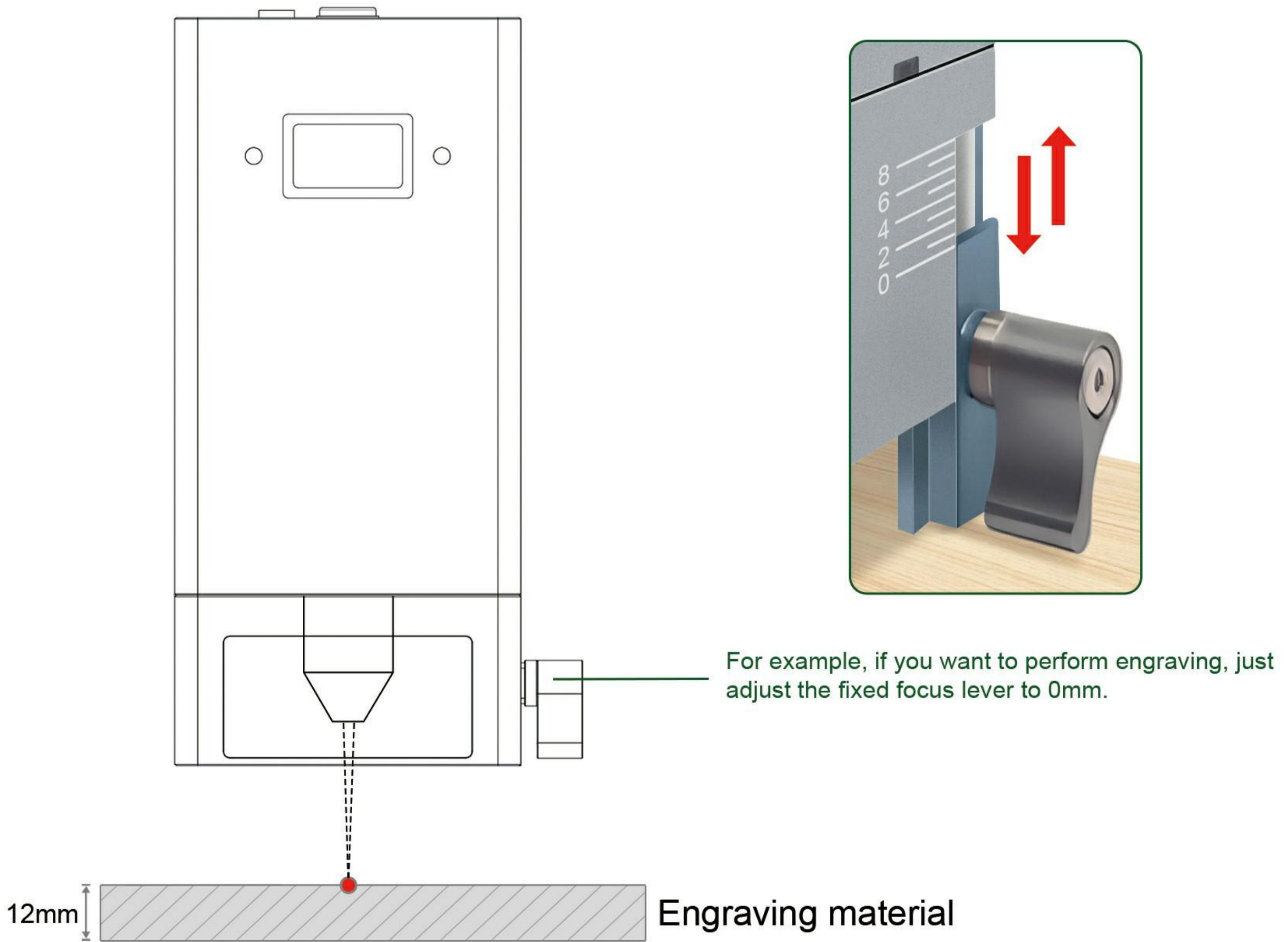

## 5. PRECAUTIONS



Laser may cause damage to your skin. Please do not expose your skin directly to the laser.



Please wear laser goggles to protect your eyes when you use this laser module.



Please ensure that the air pump is turned on before you start cutting. If not, the smoke will contaminate the lens.



This laser module doesn't support hot plug. Hot plug may cause damage to the laser module.

## 6. MAINTENANCE



When the laser module is not used for a long time, please ensure that the lens is not polluted by dust.



When you replace the air nozzle, please ensure that your operation will not pollute the lens. Finger prints or dust on the lens will weaken the output power of the laser module, or even damage the lens.



When you find the cutting ability of laser module decreased, the lens might be not clean. Please use a clean alcohol swab to clean it according to the following figure.

\* For more information about maintenance, please contact us at [lasertree@micost-optotech.com](mailto:lasertree@micost-optotech.com).







Enjoy pleasure of DIY

CE FCC RoHS  

MADE IN CHINA